



ENOC

PROTECT AND
MAXIMIZE YOUR
DATA CENTER
INVESTMENT



EDITION
OCT. 2021





WELCOME TO ENDLESS OPPORTUNITIES AND FLEXIBLE SOLUTIONS – THE ENOC WAY

Enoc focuses strongly on finding solutions and new opportunities in collaboration with its customers. This requires flexibility in both design, detail and manufacturing. Our business method has made us one of Scandinavia's leading manufacturers and suppliers of enclosures and accessories for computer network, data center and telecom installations.

Details make the difference

Enoc has a wide range of floor-standing enclosures in various sizes for server installations. Our server enclosures offer excellent value for money, and meet the requirements for different types of server room installation from both a technical and cost-effectiveness perspective. In addition, they are supplemented with a wide range of accessories. High production and delivery capacity are key factors in Enoc's operations. To ensure that we can always meet our promise to customers, we combine in-house production with a network of reliable subcontractors.

Starting with the customer's needs

A cornerstone of Enoc's business concept is to take the customer's specific needs as a starting point. This philosophy is reflected in the whole supply and production chain, from design and marketing right through to sales. It is a deciding factor for many of our customers. Our flexibility in details and solutions makes Enoc a partner you can depend on.

THE ENOC WAY

References	4	Aisle containment	18	KKT G3 Roof sections	26
Special solutions	6	CAC with underfloor cooling	20	Enoc RX System	28
Data center solution	8	HCC with room cooling	21	EPI Power distribution units	30
S1 Server enclosure	10	HAC with room cooling	22	CT Cable tray system	34
S1 CX Server enclosure	12	HAC with row cooling	23	Air control accessories	37
So1 Server enclosure	16	KKD G3 Door sections	24	The entire supply chain	38



ENOC IS A EUROPEAN SOLUTION PROVIDER THAT LISTENS TO YOUR NEEDS

At Enoc we have the knowledge and the experience to protect and maximize data center investments with solutions specially designed for their custom needs and requirements. We have a strong sales organisation with our own sales force and a network of partners throughout Europe. This enables us to provide excellent services and fast delivery worldwide. Below you can read about a few of our solutions with our customers.

Cebeo

For over 15 years we at Cebeo have been working with Enoc. We are a distributor in data communication hardware, specializing in data cabling, racks, UPS, power distribution and cooling. Our collaboration is not only the fruit of a short line communication with many of Enoc's representatives, but also the flexibility Enoc provides us in developing and deploying new products. This is an important factor in the data center environment where demands tend to evolve quickly. Our past collaborations with Enoc have been proactive and swift with such projects as the Federal Police data center, European Parliament data center and the very extensive project at FOD Finance in Belgium.

Prison and Probation Service's new data center

The Prison and Probation Services built a data center at its head office in Norrköping. For us, as the only Swedish manufacturer of server cabinet solutions, this has been a job where we have proved that knowledge and close collaboration in networks provides a good end result!

It has been stimulating to demonstrate that we have delivered in such a good and cost-effective way together with all parties involved. We not only delivered products, we also customised our deliveries directly for the site where the data center was being built. This has meant a logistics solution in close collaboration with the installation company – from our server cabinets, right down to the smallest screw.

GleSYS

"Enoc is flexible to work with and we are very satisfied with their solutions. They listen to our needs and do all they can to find the best solutions. It is easier with a supplier in the same country. Our customers span from multinationals to private clients, so it is vital to have a flexible offering. We have tried various suppliers over the years, and feel we've found the right supplier in Enoc." GleSYS was proclaimed a gazelle company in 2012. With operations in 110 countries, GleSYS has a stable basis for development. They specialise in server solutions and colocation.



“They listen
to our needs
and do all they
can to find the
best solutions.”

GleSYS





SPECIAL SOLUTIONS FOR SPECIAL DEMANDS – THE ENOC WAY

Focusing on our customer's specific needs is central in our product development, and having an eye for detail and technical design. At Enoc we are committed to finding the solution that best fits you. That is what we call "The Enoc Way".



Smart chimney solutions

A unique and space-saving cooling concept with chimneys on top of the enclosures that are designed to separate cold and hot air zones. At Enoc we have the technical expertise required to offer all types of cooling concept to improve efficiency in data centers.



Special PDU:s for special demands

If our standard PDU:s don't fit your requirements we can offer PDU:s with special configurations. Outlets – C13, C19, Schuko, French – are available in any quantity. Inlets, from 1-phase 10A C14 to 3x32A IEC. Functions, from switchable high end PDU:s to basic PDU:s with a built-in ampere meter.



Lock system adapted for custom needs

Electronic code lock system, tag readers or lock systems with adapting properties. We have a wide range of locking systems to prevent unauthorised access to equipment in the enclosures.



Freestanding Aisle Containment, FAC

Complete and customized corridor solutions to fit into different types of server rooms. Flexible solutions and quick installation. Contact us for more information.



Special corridor solutions

Our special corridor solutions can fit into different types of server rooms with low ceilings, roof sections and various types of enclosures heights.



INCREASE ENERGY EFFICIENCY AND PROTECTION STANDARD OR CUSTOM-FITTED



ENOC RX SYSTEM

Open rack system, two-post and four-post, available freestanding or wall mounted.

● See pages 28–29



FLEXIBLE AISLE CONTAINMENT

The modular door- and roof sections (KKD G3 and KKT G3) are available in different configurations and sizes.

● See pages 24–27

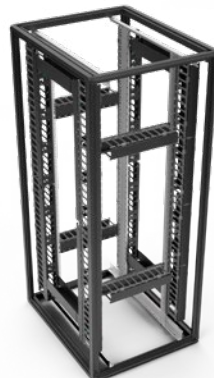
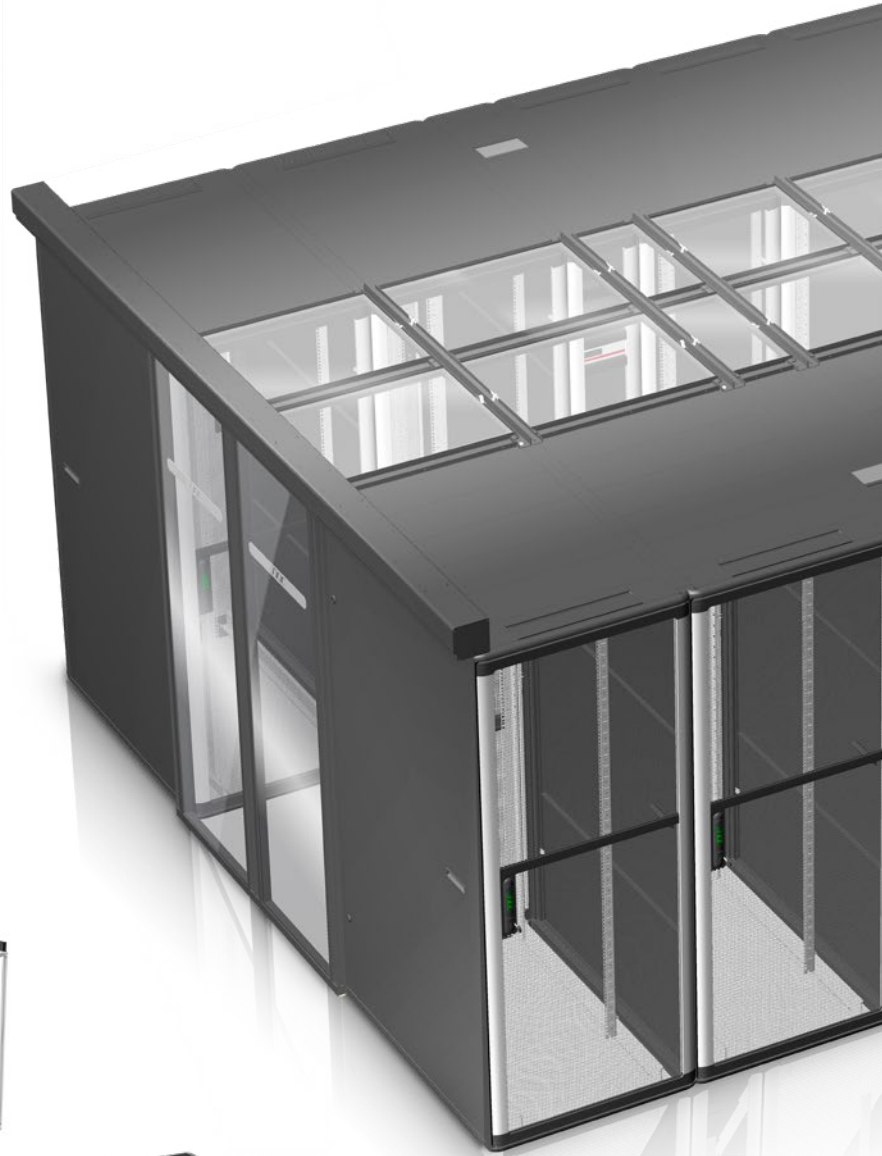

CABLE TRAY SYSTEM

A wide range of cable management products that meet your different needs.

● See pages 34–36

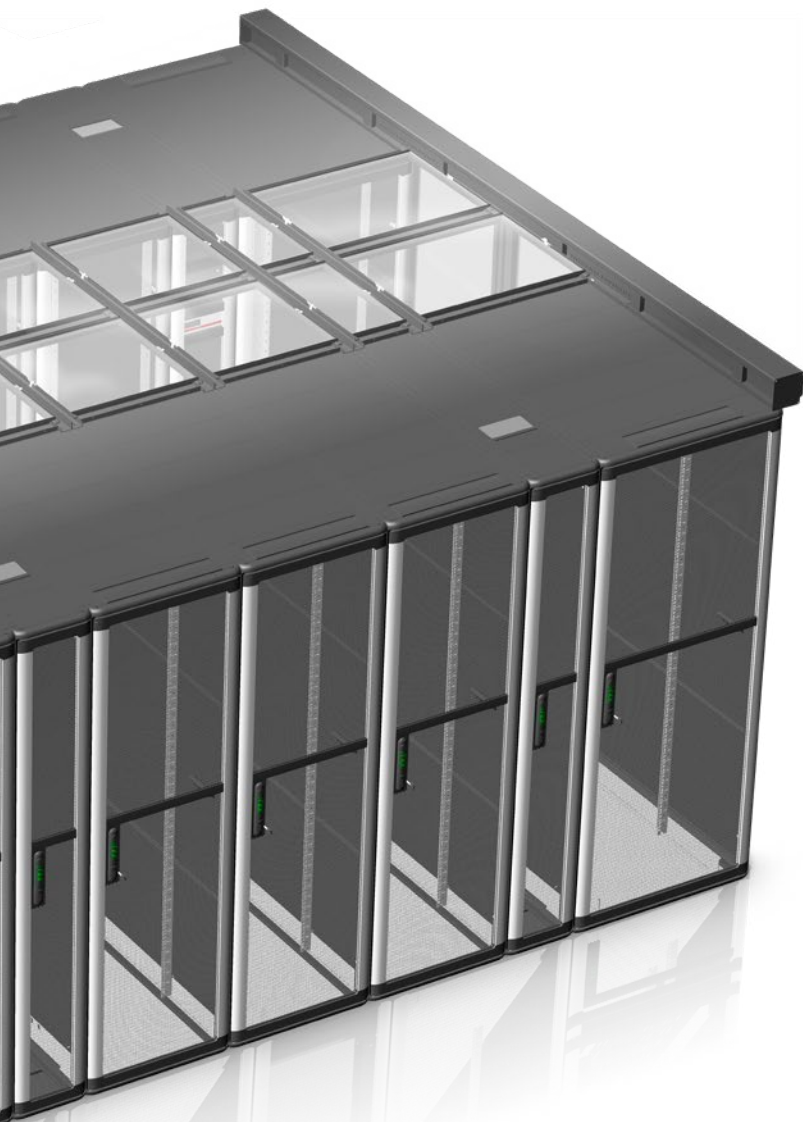

RELIABLE PDU:s, LOCAL OR REMOTE MONITORING

Our range of PDU:s (EPI serie), can be used alone as reliable power distribution units without any monitoring functionality. They can also be fitted with a monitoring module (EPI MM) for local and remote monitoring through TCP/IP.

• See pages 30-33



FORM AND FUNCTION WITH ENOC ENCLOSURES

A stepless assembly system (S1, So1 or S1 CX) easily supports your equipment, in exactly the spot you want it. With the option of off-centre positioning, you can create plenty of space, where you need it. The racks are built with aluminium profiles and support up to 1500 kilos.

• See pages 10-17





S1 SERVER ENCLOSURE

NEW DOOR, NEW HANDLE, NEW CORNER

IMPROVED AND MORE SECURE DESIGN

Enoc S1 is a series of premium server racks with optimal flexibility and stability to protect and organize your IT equipment. Upgraded design to make it even easier to assemble, disassemble and reassemble. Built with aluminium profiles with diecast zinc corners. High load capacity up to 1500 kilos. The Enoc stepless assembly system is designed to make it easier to place the equipment exactly where you want it. The S1 is assembled with screws that ensure a quick and cost-effective installation. It can be adapted as your business grows and changes. With the option of off-centre positioning, you can create plenty of space where you need it. A large space on both sides, or an extra large space on one side.

TECHNICAL INFORMATION

- Made of aluminium profiles and supports up to 1500 kilos, divided on four 19" profiles.
- Ingress protection class IP20.
- Screw-assembled frame with aluminium profiles and die-cast zinc corners. The frame has two integrated vertical screw pockets in each corner profile for universal mounting of accessories.
- Frame can be dismantled by means of screws.
- The S1 can be steplessly repositioned through the depth of the enclosure. The depth profiles have markings for precise positioning and are numbered in height units. The whole assembly can be moved right or left to an off-centre position. Enclosures with

a depth of ≤ 800 mm have one pair of 19" profiles pre-installed at a depth of 100 mm from the front of the enclosure. Enclosures with a depth of $\geq 1,000$ mm have two pairs of 19" profiles. One pair is pre-installed at a depth of 100 mm from the front of the enclosure and the other pair is pre-installed 740 mm further in.

- 1 central earthing point M5 in upright corner.

TECHNICAL DATA, BLACK

NAME	ART. NO.	EAN	E NUMBER	W x D x H (mm)	HU
S1 61012-S	56214	7330701088131	2500684	600 x 1000 x 1200	24
S1 81012-S	56219	7330701088186	2500685	800 x 1000 x 1200	24
S1 61020-S	56254	7330701088537	2500686	600 x 1000 x 2000	42
S1 61220-S	56255	7330701088544	2500687	600 x 1200 x 2000	42
S1 81020-S	56259	7330701088582	2500688	800 x 1000 x 2000	42
S1 81220-S	56260	7330701088599	2500689	800 x 1200 x 2000	42
S1 61022-S	56264	7330701088636	2500690	600 x 1000 x 2200	47
S1 61222-S	56265	7330701088643	2500691	600 x 1200 x 2200	47
S1 81022-S	56269	7330701088681	2500692	800 x 1000 x 2200	47
S1 81222-S	56270	7330701088698	2500693	800 x 1200 x 2200	47
S1 6820-S	56252	7330701088513	2503793	600 x 800 x 2000	42
S1 6822-S	56262	7330701088612	2503794	600 x 800 x 2200	47
S1 8820-S	56257	7330701088568	2503676	800 x 800 x 2000	42
S1 8822-S	56267	7330701088667	2503677	800 x 800 x 2200	47

TECHNICAL DATA, WHITE

NAME	ART. NO.	EAN	E NUMBER	W x D x H (mm)	HU
S1 61020-V	58114	7330701105135	2503785	600 x 1000 x 2000	42
S1 61220-V	58115	7330701105142	2503786	600 x 1200 x 2000	42
S1 61022-V	58124	7330701105234	2503787	600 x 1000 x 2200	47
S1 61222-V	58125	7330701105241	2503788	600 x 1200 x 2200	47
S1 81020-V	58119	7330701105180	2503789	800 x 1000 x 2000	42
S1 81220-V	58120	7330701105197	2503790	800 x 1200 x 2000	42
S1 81022-V	58129	7330701105289	2503791	800 x 1000 x 2200	47
S1 81222-V	58130	7330701105296	2503792	800 x 1200 x 2200	47

Front door

- Front door is made of 1 mm perforated sheet steel built into an aluminium frame. 85% perforation (hexagonal) on perforated surface area.
- LS 95 X1 ergonomic locking handle with C101 safety cylinder. Can be adapted for other lock systems. Integrated quick lock system allows door to be removed without use of tools.
- Door opening angle $>180^\circ$ in single enclosure configuration. Right-hinged, can be re-hung to be left-hinged.
- Also available with double doors front and rear.

Rear door

- Rear door is made of 1 mm perforated sheet steel built into an aluminium frame. 85 % perforation (hexagonal) on perforated surface area.
- LS 95 X1 ergonomic locking handle with C101 safety cylinder. Can be adapted for other lock systems. Integrated quick lock system allows door to be removed without use of tools.
- Door opening angle $>180^\circ$ in single enclosure configuration. Right-hinged, can be re-hung to be left-hinged.



SIZES

Height: 24, 42 & 47HU
 Width: 600 & 800 mm
 Depth: 1000 & 1200 mm
 Other sizes available on request.

QUALITY

Maximum static load 1500 kilos,
 divided on four 19" profiles.
 Made of aluminium profiles.
 Concealed screws.

COLOR

Black & white.
 Other RAL-colors
 on request.

EASY ASSEMBLY

Easy to assemble,
 dismantle & reassemble.

Side panels

- Sheet steel side panels, easy to detach and lockable from inside.
- Integrated handle for easier handling.

Top panels

- The top consists of replaceable modular pa-

nels. One panel has cable glands with brush strip on the back and the rest are cover plates. Can be replaced with ventilation panels, fan packages or panels with integrated cable glands. All modules can be rotated 90° and assembled with the cable glands on the left and/or right side. The U-shaped panel

with integrated cable glands makes it easy to move pre-existing installations into the enclosure.

Bottom

- The base is open, but can be fitted with cover plate/base plate packages.



S1 CX SERVER ENCLOSURE THE PERFECT SOLUTION FOR COLOCATION SETUPS

The new Enoc S1 CX is a series of server enclosures built to optimize and increase security in colocation or data centers. Each cabinet can be built with 2, 3 or 4 compartments, separated by a shelf. It is built with the Enoc S1 frame which means the same stability and interior design and all standard accessories will fit. The S1 CX is assembled with screws ensuring a quick and cost effective installation. At Enoc we are committed to finding the solution that best fits you. That is what we call “The Enoc Way”.

TECHNICAL INFORMATION

- 2000 and 2200 mm high enclosure in 2, 3 or 4 compartments. Possible with more compartments on request.
- S1 standard frame. Built with aluminium profiles and supports up to 1500 kilos, divided on four 19" profiles.
- Ingress protection class IP20.
- Screw-assembled frame with aluminium profiles and die-cast zinc corners. The frame has two integrated vertical screw pockets in each corner profile for universal mounting of accessories.
- Frame can be dismantled by means of screws.
- The S1 CX can be steplessly repositioned through the depth of the enclosure. The depth profiles have markings for precise positioning and are numbered in height units. The whole assembly can be moved right or left to an off-centre position. All enclosures have two pairs of 19" profiles for each compartment. One pair is pre-installed at a depth of 100 mm from the front of the enclosure and the other pair is pre-installed 740 mm further in. 1 central earthing point M5 in upright corner.

Front door and back door

- 1 mm perforated sheet steel built into an aluminium frame. 85% perforation on perforated surface area.
- LS 85 ergonomic locking handle with C101 safety cylinder. Can be adapted for other lock systems.
- Integrated quick lock system allows door to be removed without use of tools.
- Door opening angle >180° in single enclosure configuration. Right-hinged, can be re-hung to be left-hinged.

Side panels

- Sheet steel side panels, easy to detach, lockable from inside and from more than one compartment. One full size panel, not divided into 2/3/4 compartments.
- Integrated handle for easier handling.

Top panels

- The top consists of replaceable modular panels. One panel has cable glands with brush strip on the back and the rest are cover plates. Can be replaced with ventilation panels, fan packages or panels with integrated cable glands. All modules can be rotated 90° and assembled with the cable glands on the left and/or right side. The U-shaped panel with integrated cable glands makes it easy to move pre-existing installations into the enclosure.

Bottom

- The base is open, but can be fitted with cover plate/base plate packages.



SIZES

Height: 42HU & 47HU
Width: 600 & 800 mm
Depth: 1000 & 1200 mm

SECURITY

Locking system ensures access for authorised staff only.

COMPARTMENTS

2, 3 or 4 compartments. Possible with more compartments on request.

QUALITY

1500 kg, divided on four 19" profiles. S1 standard frame. Made of aluminium profiles. Concealed screws.



S1 CX SERVER ENCLOSURE

TECHNICAL DATA S1 C2

NAME	ART. NO.	EAN	E NUMBER	W x D x H (mm)	REMARK
S1 C2 61020-S	57301	7330701098000	2501443	600 x 1000 x 2000	2 x 20 HU
S1 C2 81020-S	57306	7330701098055	2501446	800 x 1000 x 2000	2 x 20 HU
S1 C2 61220-S	57311	7330701098109	2501449	600 x 1200 x 2000	2 x 20 HU
S1 C2 81220-S	57316	7330701098154	2501452	800 x 1200 x 2000	2 x 20 HU
S1 C2 61022-S	57321	7330701098208	2501455	600 x 1000 x 2200	2 x 22 HU
S1 C2 81022-S	57326	7330701098253	2501458	800 x 1000 x 2200	2 x 22 HU
S1 C2 61222-S	57331	7330701098307	2501461	600 x 1200 x 2200	2 x 22 HU
S1 C2 81222-S	57336	7330701098352	2501464	800 x 1200 x 2200	2 x 22 HU

TECHNICAL DATA S1 C3

NAME	ART. NO.	EAN	E NUMBER	W x D x H (mm)	REMARK
S1 C3 61020-S	57302	7330701098017	2501444	600 x 1000 x 2000	3 x 12 HU
S1 C3 81020-S	57307	7330701098062	2501447	800 x 1000 x 2000	3 x 12 HU
S1 C3 61220-S	57312	7330701098116	2501450	600 x 1200 x 2000	3 x 12 HU
S1 C3 81220-S	57317	7330701098161	2501453	800 x 1200 x 2000	3 x 12 HU
S1 C3 61022-S	57322	7330701098215	2501456	600 x 1000 x 2200	3 x 14 HU
S1 C3 81022-S	57327	7330701098260	2501459	800 x 1000 x 2200	3 x 14 HU
S1 C3 61222-S	57332	7330701098314	2501462	600 x 1200 x 2200	3 x 14 HU
S1 C3 81222-S	57337	7330701098369	2501465	800 x 1200 x 2200	3 x 14 HU

TECHNICAL DATA S1 C4

NAME	ART. NO.	EAN	E NUMBER	W x D x H (mm)	REMARK
S1 C4 61020-S	57303	7330701098024	2501445	600 x 1000 x 2000	4 x 9 HU
S1 C4 81020-S	57308	7330701098079	2501448	800 x 1000 x 2000	4 x 9 HU
S1 C4 61220-S	57313	7330701098123	2501451	600 x 1200 x 2000	4 x 9 HU
S1 C4 81220-S	57318	7330701098178	2501454	800 x 1200 x 2000	4 x 9 HU
S1 C4 61022-S	57323	7330701098222	2501457	600 x 1000 x 2200	4 x 10 HU
S1 C4 81022-S	57328	7330701098277	2501460	800 x 1000 x 2200	4 x 10 HU
S1 C4 61222-S	57333	7330701098321	2501463	600 x 1200 x 2200	4 x 10 HU
S1 C4 81222-S	57338	7330701098376	2501466	800 x 1200 x 2200	4 x 10 HU

S1 C2 • 2 compartments



View of inner framework

S1 C3 • 3 compartments



View of inner framework

S1 C4 • 4 compartments



View of inner framework



So1 OPEN SERVER FRAME

EASY ACCESS AND PLENTY OF OPEN SPACE

Enoc So1 is a series of open frame server-racks without sides or doors. Perfect for applications that don't require physical security. The So1 has a stable interior that supports loads up to 1500 kilos. The Enoc stepless assembly system is designed to make it easy to place the equipment exactly where you want it. The frame is assembled with nothing but screws, making it easy to assemble, dismantle and reassemble. The So1 can be adapted as your business grows and changes. The So1:s rounded corners give a nice sleek look. The concealed screws and aluminium profiles contribute to a streamlined appearance. With the option of off-centre positioning, you can create plenty of space where you need it. A large space on both sides, or an extra large space on one side.

TECHNICAL INFORMATION

- Made of aluminium profiles and supports up to 1500 kilos, divided on four 19" profiles.
 - Ingress protection class IP20.
 - Screw-assembled frame with aluminium profiles and die-cast zinc corners. The frame has two integrated vertical screw pockets in each corner profile for universal mounting of accessories.
 - Frame can be dismantled by means of screws.
 - The So1 can be steplessly repositioned through the depth of the enclosure. The depth profiles have markings for precise positioning and are numbered in height units. The whole assembly can be moved right or left to an off-centre position. Enclosures with a depth of ≤ 800 mm have one pair of 19" profiles pre-installed at a depth of 100 mm from the front of the enclosure. Enclosures with a depth of $\geq 1,000$ mm have two pairs of 19" profiles. One pair is pre-installed at a depth of 100 mm from the front of the enclosure and the other pair is pre-installed 740 mm further in.
 - 1 central earthing point M5 in upright corner.
- Open frame**
- So1-frame has no doors or side panels. Can be supplemented with doors and side panels from our range of accessories.
- Top panels**
- The top consists of replaceable modular panels. One panel has cable glands with brush strip on the back and the rest are cover plates. Can be replaced with ventilation panels, fan packages or panels with integrated cable glands. All modules can be rotated 90° and assembled with the cable glands on the left and/or right side. The U-shaped panel with integrated cable glands makes it easy to move pre-existing installations into the enclosure.
- Bottom**
- The base is open, but can be fitted with cover plate/base plate packages.

TECHNICAL DATA

NAME	ART. NO.	EAN	E NUMBER	W x D x H (mm)	HU
So1 61012-S	56314	7330701089138	2500694	600 x 1000 x 1200	24
So1 81012-S	56319	7330701089183	2500695	800 x 1000 x 1200	24
So1 61020-S	56354	7330701089534	2500696	600 x 1000 x 2000	42
So1 61220-S	56355	7330701089541	2500697	600 x 1200 x 2000	42
So1 81020-S	56359	7330701089589	2500698	800 x 1000 x 2000	42
So1 81220-S	56360	7330701089596	2500699	800 x 1200 x 2000	42
So1 61022-S	56364	7330701089633	2500700	600 x 1000 x 2200	47
So1 61222-S	56365	7330701089640	2500701	600 x 1200 x 2200	47
So1 81022-S	56369	7330701089688	2500702	800 x 1000 x 2200	47
So1 81222-S	56370	7330701089695	2500703	800 x 1200 x 2200	47



SIZES

Height: 24, 42 & 47HU
Width: 600 & 800 mm
Depth: 1000 & 1200 mm
Other sizes available on request.

QUALITY

Maximum static load 1500 kilos,
divided on four 19" profiles.
Made of aluminium profiles.
Concealed screws.

COLOR

Black RAL 9005.
Other RAL-colors on
request.

EASY ACCESS

Open frame ensures
easy access.



INTRODUCING THE THIRD GENERATION OF AISLE CONTAINMENT SYSTEM

A totally new aisle containment system with complete hot and cold air separation. Optimizing air flow in your data center with the use of containment has several benefits, including reducing energy costs and improving efficiency. The right choice of a cooling system gives the data center an optimal temperature. Our new aisle containment solutions separate hot from cold aisles by the roof and door sections. Together with our cooling systems, locking system and monitoring PDU:s, you have a complete future-proof and sustainable solution.

Maximum energy efficiency

Separating the hot and cold aisles with a containment solution stops hot air recirculating and mixing with the cold inlet air. This type of recirculation reduces overall cooling efficiency and prevents the long-life of the equipment. Air cooling, where cool outside air is led into the cooling devices, is an ecological solution that is very well suited for data centers. Cooling generates excess heat that can then be used to heat the office or stairwells.

New design with maximum flexibility

KKD G3 and KKT G3 are a series of products that are required to build aisle

containments with S1 server enclosures. All new design with door beam from end to end of cabinet with aluminum cover in one single piece. Integrated handles in the aluminum frame of doors. And roof sections of steel and glass. Almost all aisle containment projects require some special considerations. Therefore, all KKD G3 and KKT G3 are available in different configurations and sizes. At Enoc we will solve whatever challenges that can occur.

Minimal installation time

Our door- and roof sections easily fit with our server enclosure S1 and ensure a quick and cost-effective installation.



REDUCE ENERGY COSTS

The system works effectively while reducing power consumption and energy costs.



INCREASE FLEXIBILITY

Extremely stable and smooth running. 4 function levels; manual, synchronic, self-closing or automatic.

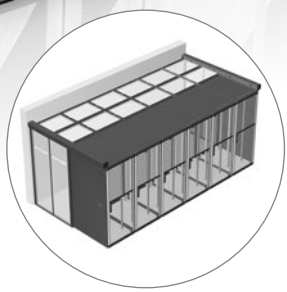

DOOR SYSTEMS

With the door section KKD G3 you easily manage airflow and security.



ROOF SYSTEMS

KKT G3 is a series of modular and scalable roof sections of steel and glass.



CAC WITH UNDERFLOOR COOLING

CAC, Cold Aisle Containment, is one of Enoc's flexible aisle containment solutions for data centers and server rooms. Floor cooling with perforated tiles in the cold aisle, which requires raised floors. Can be retrofitted in existing data centers.



A flexible system

A flexible and scalable system for smart infrastructure in server rooms and data centers. Enoc's modular system is easy to assemble and supplement. A solution that lasts as your business grows and changes. The film shows how CAC with underfloor cooling works.

Energy saving room cooling

A cost- and energy-efficient aisle containment solution that makes your data center investment last longer. By separating and circulating the hot and

cold air streams, large savings are made possible. Cold air is spread through the raised floor and provides efficient cooling of the IT equipment.

Customized solutions

CAC with underfloor cooling is a solution for hot and cold aisles that fits perfectly with our server cabinet series S1, built with aluminum profiles and in a quality that can withstand 1500 kg. Supplement with flexible roof and door sections for a fully customized solution based on your needs.



1. KKT G3 Roof sections
2. KKD G3 Door sections
3. S1 Server Cabinet



HCC WITH ROOM COOLING

HCC, Hot Chimney Containment, our chimney solutions with room cooling are available in different dimensions. Allows flexible placement of racks and cabinets. The design is self-supporting and requires no fixing in top. Cools the entire room.

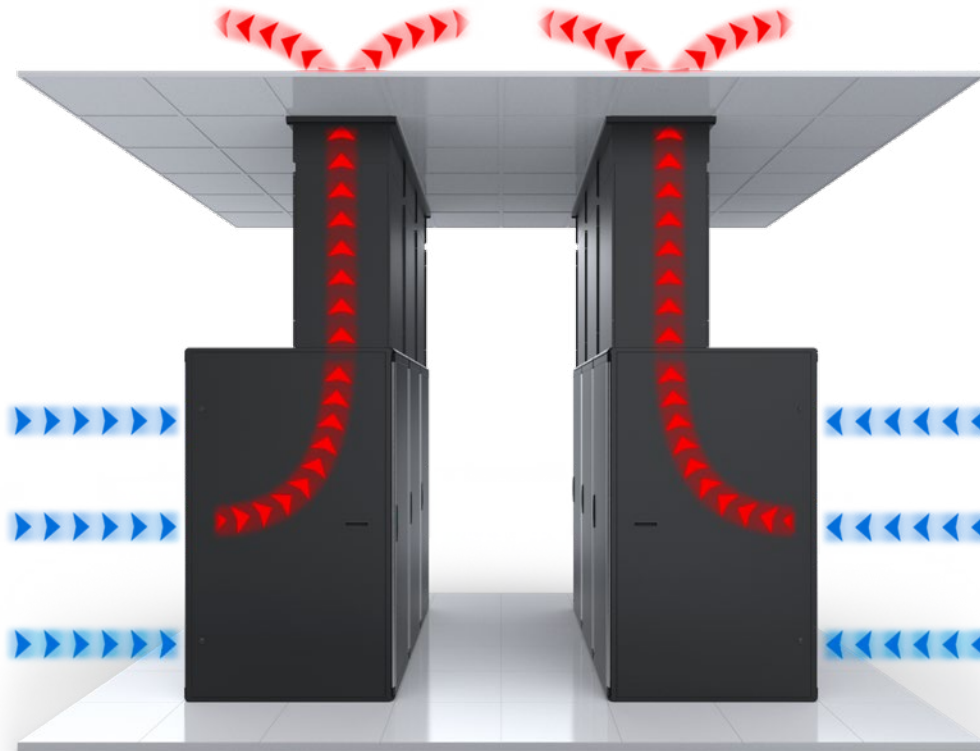

Flexible placement

Server racks and cabinets can be placed freely when it comes to cooling. With the back door closed, airflow is led up through the chimney. The whole room is cold, no need for cold or hot corridors. The chimneys are available in different dimensions. The film shows how HCC with room cooling works.

Maximum energy efficiency

Containment systems prevent the hot discharge air from the cooler supply air, managing cooling by separating the

airflow. This separation is important to reduce excess heat and “hot spots”, as it has a negative impact on the equipment’s performance and greatly reduces the service life.

A complete system

HCC is a smart chimney solution that cools the entire room. Our aisle containments provide a complete, future-proof and sustainable solution. In addition, they are easy to install. Efficient and flexible with endless possibilities.



1. HCC Chimney
2. S1 Server Cabinet adapted to HCC cooling



HAC WITH ROOM COOLING

HAC, Hot Aisle Containment with room cooling. Recessed roof with hot air return to cooling units provides high efficiency and energy savings. For hot aisle containment in any dimension. Thanks to the flexible and scalable system, it is possible to customize solutions.

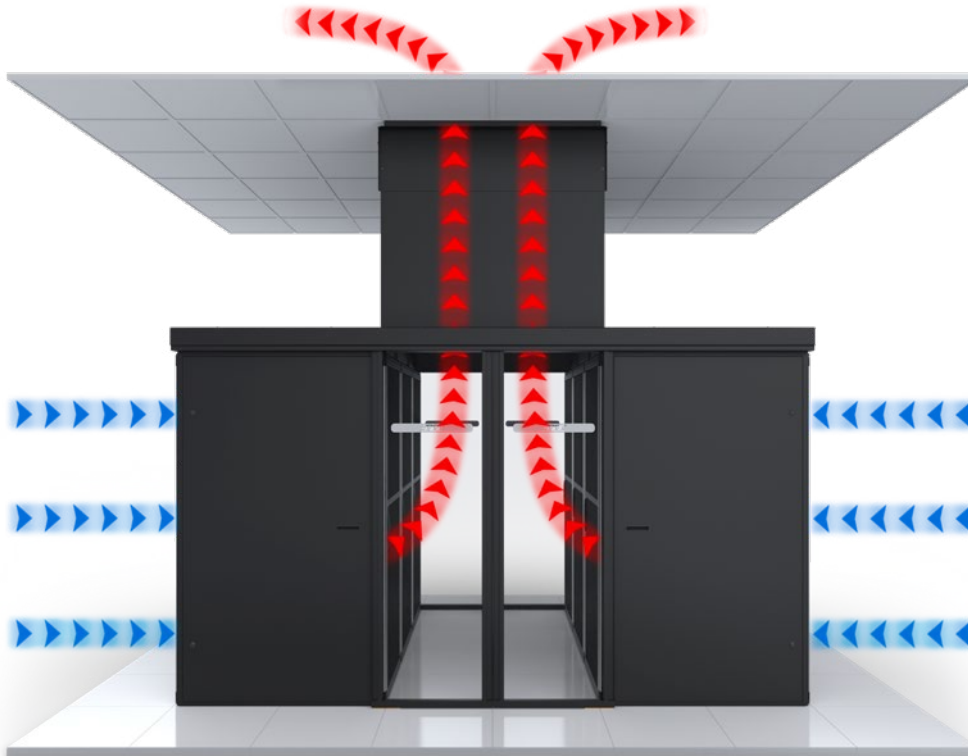

Any dimension for maximum flexibility

Enoc's modular system is flexible, scalable and easy to assemble. The design is self-supporting and requires no fixing in top. Keeps the whole room cold. The film shows how HAC with room cooling works.

Cooling the entire room

Optimizing the airflow in your data center with the use of containment solutions has several benefits, including reducing energy costs and improving efficiency. The right choice of cooling system gives

the data center an optimal temperature. Our hot and dense aisles prevent the circulation of hot air from being mixed with the cold inlet air.

Space saving solutions

HAC with room cooling provides a stable and quiet solution to protect data centers in confined spaces. Our special corridor solutions fit into different types of server rooms with low ceilings, different roof sections and various cabinet heights.



1. HAC Hot Aisle Containment
2. KKD G3 Door sections
3. S1 Server Cabinet

HAC WITH ROW COOLING

HAC, Hot Aisle Containment with row cooling, provides high efficiency and energy savings. Thanks to the flexible and scalable system, it is possible to customize solutions that provide high redundancy and efficient airflows.

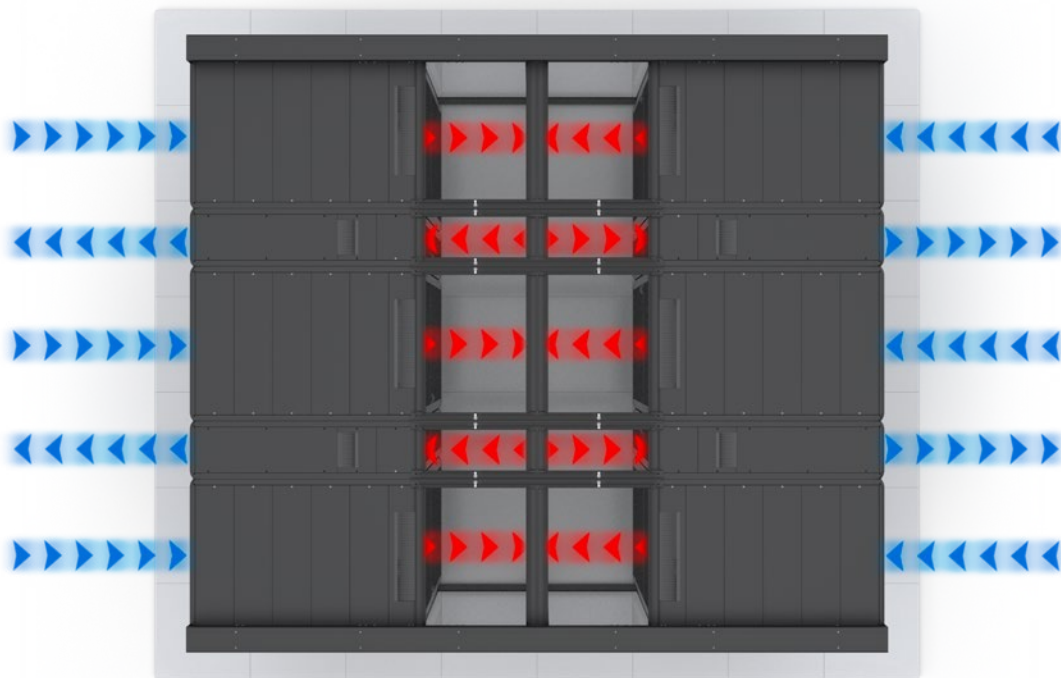

Customized solutions

Enoc's modular system is easy and flexible, easy to assemble, supplement, disassemble and reassemble. A scalable solution that grows as your business changes. The film shows how HAC with row cooling works.

Energy saving row cooling

Scalable system where the number of cooling units can be scaled and customized to your needs. The cooling units are close to the computer load, which gives the best effect where it is needed. The

hot and dense aisles keep the entire room cold. Smaller cooling units provide high redundancy, which means a cost-effective solution.

A total solution

HAC with row cooling is one of Enoc's aisle containment solutions for cold/hot rows. Fits with S1 server rack. Supplement with cooling units as well as roof and door sections for a flexible and customized solution. No need for raised floor or recessed ceiling.

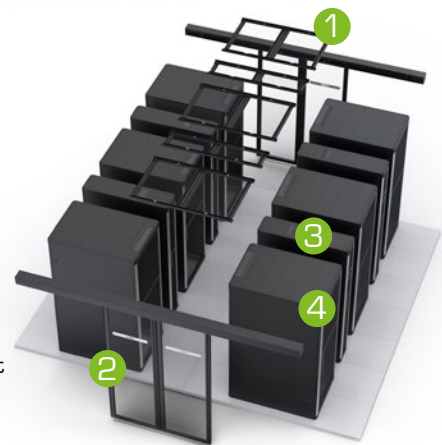

1. KKT G3 Roof sections
2. KKD Door sections
3. EHDC Cooling units
4. S1 Server Cabinet



KKD G3 DOOR SECTIONS

KKD G3 is a series of flexible door sections for creating aisle containments together with S1 server enclosures. Standard models for 1200 mm aisle width and cabinet height of 2000 and 2200 mm. Door sections in customized aisle widths are available on request. Four function levels: manual, synchronic, self-closing and automatic.

Manual

Each door blade is manually operated.

Synchronic

Left and right door blade with simultaneous running. Pushing one will automatically operate the other (only in two door versions).

Self-closing

Door blades are spring operated. Doors will self-close when released. System includes soft-close system that catches the door blades the last part and gently closes the door section.

Automatic

Door blades are operated with an electric motor. The system contains two radars, one of each side of the door, that triggers door opening. The doors will self-close when untriggered.

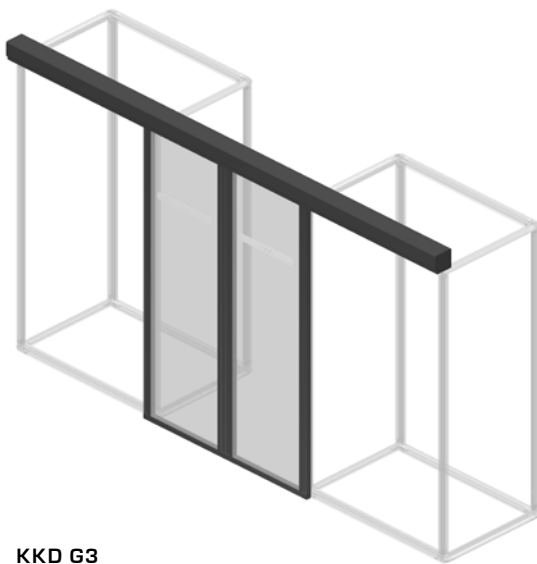

KKD G3

Double door configuration.

Fixing on two Enoc S1 racks (1000 or 1200 mm deep and 2000 or 2200 mm high).

Standard aisle width of 1200 mm. Other widths available on request.

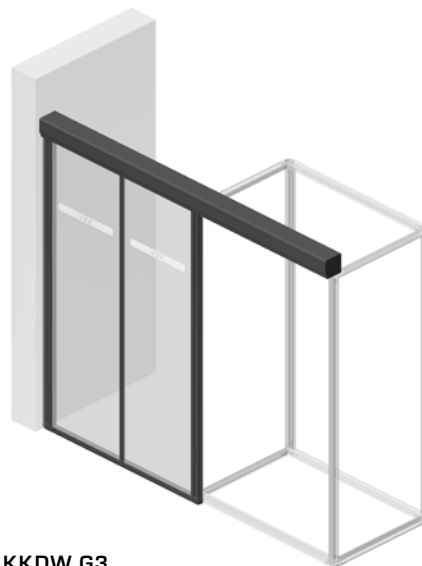

KKDW G3

Single door configuration for single row aisle close to a wall.

Fixing on one Enoc S1 rack (1000 or 1200 mm deep and 2000 or 2200 mm high) and on to a wall.

Standard aisle width of 1200 mm. Other widths available on request.

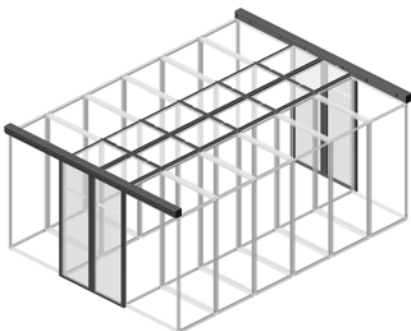

KKD G3 + KKT G3

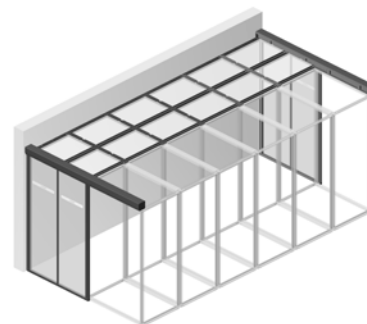

KKDW G3 + KKTW G3

TECHNICAL INFORMATION

- Extremely stable door beam from end to end of cabinet. Aluminum cover in one single piece.
- 4 function levels: Manual, Synchronic, Self-closing, Automatic.
- KKD G3 for two row aisles and KKDW G3 for one row aisles next to a wall.
- Door blade in 4 mm in fully tempered security glass framed in an aluminum frame with built in handles.
- Free walking height is the same as cabinet height, 2000 or 2200 mm.
- Finish: Enoc textured black RAL 9005.
- Delivered unmounted including all fixing material.
- Art no 57979, KKTW G3 Wall-fixing required for wall-fixing of KKDW.

TECHNICAL DATA – KKD G3

NAME	ART. NO.	EAN	AISLE WIDTH (mm)	MAX OPENING (mm)	CABINET HEIGHT (mm)	TOTAL WIDTH (mm)	FUNCTION
KKD G3 1220 32-M	57901	7330701098505	1200	1030	2000	3200	M*
KKD G3 1220 32-S	57902	7330701098512	1200	1030	2000	3200	S*
KKD G3 1220 32-SC	57903	7330701098529	1200	1030	2000	3200	SC*
KKD G3 1220 32-A	57904	7330701098536	1200	1030	2000	3200	A*
KKD G3 1220 36-M	57906	7330701098550	1200	1030	2000	3600	M*
KKD G3 1220 36-S	57907	7330701098567	1200	1030	2000	3600	S*
KKD G3 1220 36-SC	57908	7330701098574	1200	1030	2000	3600	SC*
KKD G3 1220 36-A	57909	7330701098581	1200	1030	2000	3600	A*
KKD G3 1222 32-M	57911	7330701098604	1200	1030	2200	3200	M*
KKD G3 1222 32-S	57912	7330701098611	1200	1030	2200	3200	S*
KKD G3 1222 32-SC	57913	7330701098628	1200	1030	2200	3200	SC*
KKD G3 1222 32-A	57914	7330701098635	1200	1030	2200	3200	A*
KKD G3 1222 36-M	57916	7330701098659	1200	1030	2200	3600	M*
KKD G3 1222 36-S	57917	7330701098666	1200	1030	2200	3600	S*
KKD G3 1222 36-SC	57918	7330701098673	1200	1030	2200	3600	SC*
KKD G3 1222 36-A	57919	7330701098680	1200	1030	2200	3600	A*

* M – Manual, S – Synchronic, SC – Self Closing (including Synchronic), A – Automatic

TECHNICAL DATA – KKDW G3

NAME	ART. NO.	EAN	AISLE WIDTH (mm)	MAX OPENING (mm)	CABINET HEIGHT (mm)	TOTAL WIDTH (mm)	FUNCTION	LEFT/ RIGHT
KKDW G3 1220L 22-M	57921	7330701098703	1200	880	2000	2200	M*	L**
KKDW G3 1220R 22-M	57922	7330701098710	1200	880	2000	2200	M*	R**
KKDW G3 1220L 22-SC	57923	7330701098727	1200	880	2000	2200	SC*	L**
KKDW G3 1220R 22-SC	57924	7330701098734	1200	880	2000	2200	SC*	R**
KKDW G3 1220L 22-A	57925	7330701098741	1200	880	2000	2200	A*	L**
KKDW G3 1220R 22-A	57926	7330701098758	1200	880	2000	2200	A*	R**
KKDW G3 1220L 24-M	57931	7330701098802	1200	1080	2000	2400	M*	L**
KKDW G3 1220R 24-M	57932	7330701098819	1200	1080	2000	2400	M*	R**
KKDW G3 1220L 24-SC	57933	7330701098826	1200	1080	2000	2400	SC*	L**
KKDW G3 1220R 24-SC	57934	7330701098833	1200	1080	2000	2400	SC*	R**
KKDW G3 1220L 24-A	57935	7330701098840	1200	1080	2000	2400	A*	L**
KKDW G3 1220R 24-A	57936	7330701098857	1200	1080	2000	2400	A*	R**
KKDW G3 1222L 22-M	57941	7330701098901	1200	880	2200	2200	M*	L**
KKDW G3 1222R 22-M	57942	7330701098918	1200	880	2200	2200	M*	R**
KKDW G3 1222L 22-SC	57943	7330701098925	1200	880	2200	2200	SC*	L**
KKDW G3 1222R 22-SC	57944	7330701098932	1200	880	2200	2200	SC*	R**
KKDW G3 1222L 22-A	57945	7330701098949	1200	880	2200	2200	A*	L**
KKDW G3 1222R 22-A	57946	7330701098956	1200	880	2200	2200	A*	R**
KKDW G3 1222L 24-M	57951	7330701099007	1200	1080	2200	2400	M*	L**
KKDW G3 1222R 24-M	57952	7330701099014	1200	1080	2200	2400	SC*	L**
KKDW G3 1222L 24-SC	57953	7330701099021	1200	1080	2200	2400	A*	L**
KKDW G3 1222R 24-SC	57954	7330701099038	1200	1080	2200	2400	M*	R**
KKDW G3 1222L 24-A	57955	7330701099045	1200	1080	2200	2400	SC*	R**
KKDW G3 1222R 24-A	57956	7330701099052	1200	1080	2200	2400	A*	R**

* M – Manual, SC – Self Closing, A – Automatic

** L – Left [aisle to the left of cabinet seen from outside the aisle], R – Right [aisle to the right of the cabinet seen from outside the aisle]



KKT G3 ROOF SECTIONS

KKT G3 is a series of flexible roof sections for creating aisle containments together with S1 server enclosures. Standard models for 1200 mm aisle width and cabinet widths of 800, 600 and 300 mm. Two function levels: standard and radar.

Standard

Standard roof for aisle containment.

Radar

Roof section for fitting next to a KKD G3 Automatic. This roof section holds the radar inside the aisle in ideal position.

TECHNICAL INFORMATION

- Extremely stable frame of steel sheet.
- Roof tiles of 4 mm fully tempered security glass, hold in place with slotted lock.
- Free walking height is the same as cabinet height, 2000 or 2200 mm.
- Finish: Enoc textured black RAL 9005.
- Delivered mounted including all fixing material.
- Art no 57979, KKTW G3 Wall-fixing required for wall-fixing of KKTW.

KKT G3

Fixing on two Enoc S1 racks (1000 or 1200 mm deep and 2000 or 2200 mm high).
Standard aisle width of 1200 mm. Other widths available on request.

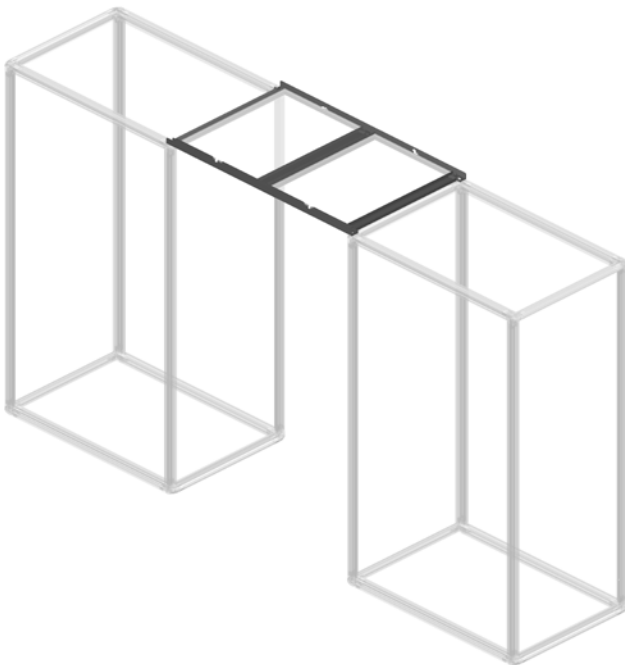

KKT G3 Standard

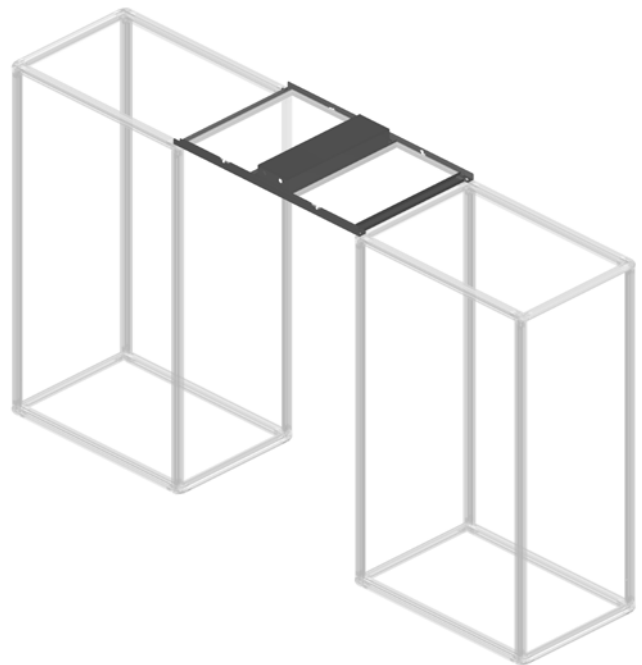

KKT G3 Radar

TECHNICAL DATA - KKT G3/KKTW G3

NAME	ART. NO.	EAN	AISLE WIDTH (mm)	CABINET WIDTH (mm)	FUNCTION
KKT G3 123	57961	7330701099106	1200	300	
KKT G3 126	57962	7330701099113	1200	600	
KKT G3 128	57963	7330701099120	1200	800	
KKT G3 123 Radar	57966	7330701099151	1200	300	RAD***
KKT G3 126 Radar	57967	7330701099168	1200	600	RAD***
KKT G3 128 Radar	57968	7330701099175	1200	800	RAD***
KKTW G3 123	57971	7330701099205	1200	300	
KKTW G3 126	57972	7330701099212	1200	600	
KKTW G3 128	57973	7330701099229	1200	800	
KKTW G3 123 Radar	57976	7330701099250	1200	300	RAD***
KKTW G3 126 Radar	57977	7330701099267	1200	600	RAD***
KKTW G3 128 Radar	57978	7330701099274	1200	800	RAD***

*** RAD - Roof section for radar sensor (placed directly next to KKT G3 door section (Automatic))

ACCESSORIES

NAME	ART. NO.	EAN	LENGTH (mm)	CABINET WIDTH (mm)	FUNCTION
KKTW G3 Wall-fixing	57979	7330701099281	2400	300	****
IBS 3 X1-S	57108	7330701096075			

**** 2400 mm wall-fixing. For 3 x KKTW G3 128 or 4 x KKTW G3 126. Required for KKDW or KKTW.

KKTW G3

Roof configuration for single row aisle close to a wall.

Fixing on one Enoc S1 rack and next to a wall.

Aisle width: 1200 mm +/-5 mm. Other widths available on request.

Requires KKTW G3 Wall-fixing accessory.

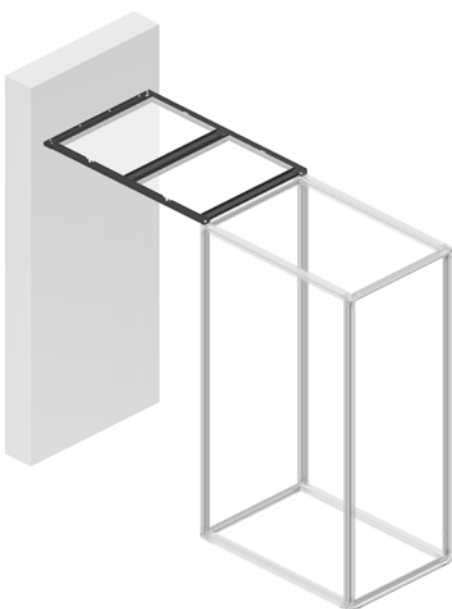

KKTW G3 Standard

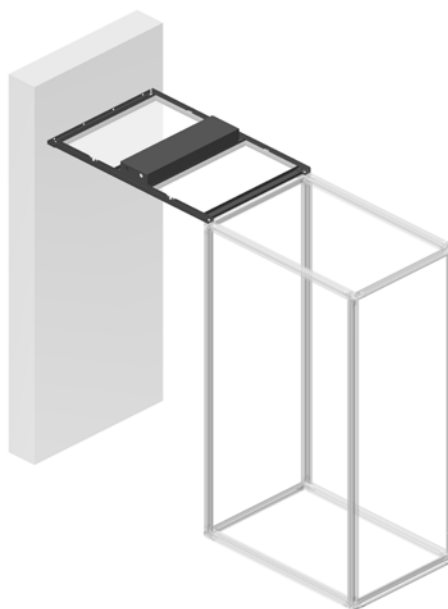

KKTW G3 Radar

ACCESSORIES

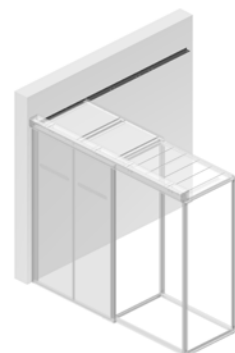

KKTW G3 Wall-fixing



IBS 3 X1-S



ENOC RX SYSTEM

TWO-POST AND FOUR-POST RACK SYSTEM

Enoc RX is a system of open server racks, especially suitable for dedicated server rooms as they save space, provide easier access and simplify cable management. Create your own unique solution with our premium rack combined with our various wall and door solutions. The RX System is a modular system suitable both for networks and complete data center solutions thanks to the flexible design and the wide range of accessories. The possibilities are almost endless.



R1 – Four-post rack

An open and flexible solution that provides the same stability as a server cabinet. Cost-effective and space-saving for large and small installations. Adjustable in depth.



R2 – Two-post rack, free standing

Smart premium solution that uses less floor space than a server cabinet or a four-post rack. Stable and flexible.



R3 – Two-post rack, wall fixed

Open wall mounted server rack for easy access to cables and equipment. Suitable for high density cabling.

TECHNICAL INFORMATION

Open four-post rack with 19" front and back

- Depth 600–900 mm (in 50 mm steps)
- Static load capacity, 1000 kg
- Width 526 mm
- Height 2000 mm/42 HU and 2200 mm/47 HU
- HU marking
- All fixing material included
- Manufactured in steel sheet
- Surface treatment, black structured paint RAL 9005

Open two-post rack with 19" front and back

- Depth 170 mm (450 mm with feet)
- Static load capacity, 500 kg (centralized)
- Width 526 mm
- Height 2000 mm/42 HU and 2200 mm/47 HU
- HU marking
- All fixing material included
- Manufactured in steel sheet
- Surface treatment, black structured paint RAL 9005

Open two-post rack with 19" front

- Depth 555–855 mm (in 50 mm steps)
- Static load capacity, 250 kg (centralized)
- Width 526 mm
- Height 2000 mm/42 HU and 2200 mm/47 HU
- HU marking
- All fixing material included
- Manufactured in steel sheet
- Surface treatment, black structured paint RAL 9005

TECHNICAL DATA – R1, R2 AND R3

NAME	ART. NO	EAN	E NUMBER	WxDxH (mm)	HU
R1 42-S	58301	7330701105517	2503811	526x600-900x2000	42
R1 47-S	58302	7330701105524	2503812	526x600-900x2200	47
R2 42-S	58304	7330701105548	2503813	526x170/450x2003	42
R2 47-S	58305	7330701105555	2503814	526x170/450x2203	47
R3 42-S	58307	7330701105579	2503815	526x555-855x2000	42
R3 47-S	58308	7330701105586	2503816	526x555-855x2200	47

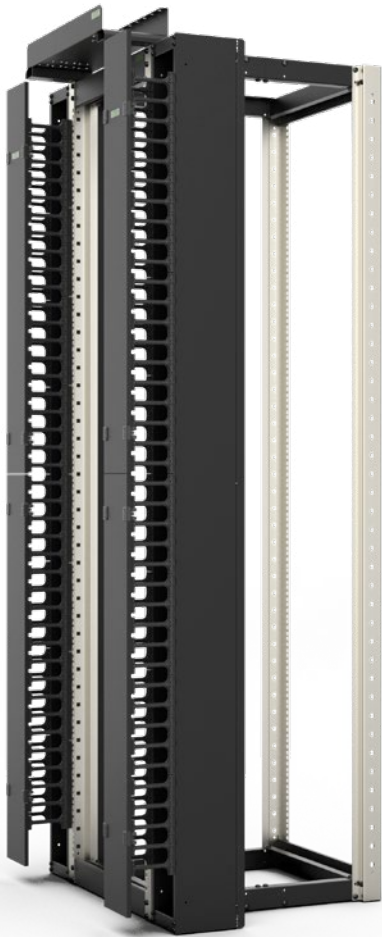

R1 - Four-post rack

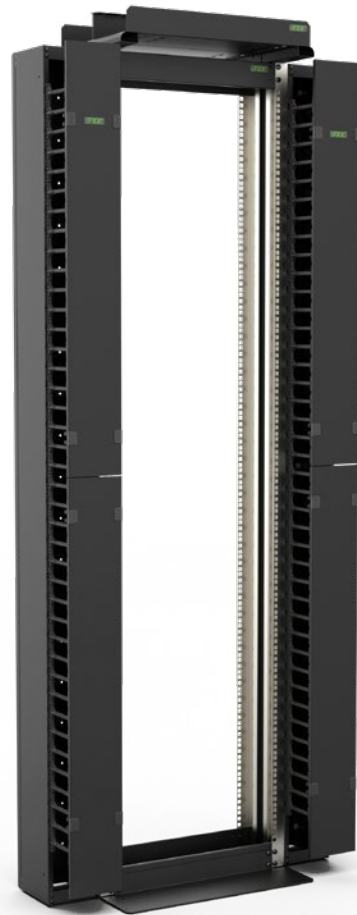

R2 - Two-post rack, free standing

QUALITY

Premium quality.
Steel sheet

EASY ACCESS

Fast and flexible handling
Saving space

THREE VERSIONS, TWO SIZES

Width 526 mm, 42 & 47 HU

FAST DELIVERY

Available for immediate delivery



R3 - Two-post rack, wall fixed



EPI G2 RELIABLE POWER DISTRIBUTION UNITS

EPI G2 is a range of PDU:s that can be used alone as reliable power distribution unit without any monitoring functionality. The PDU can be fitted with a monitoring module (EPI MM G2) for local and remote monitoring through TCP/IP or ampere module (EPI AM G2) for local ampere reading.



EPI PDU

- PDU with C13 and C19 outlets in multiple configurations.
- Multiple inlet options.
- PDU will provide power regardless if a monitoring module is fitted or not.
- Possible to add EPI MM monitoring module or EPI AM ampere module.
- Custom configuration of inlet and outlet available on request.

EPI MM, MONITORING MODULE

Each EPI PDU can be used alone to provide reliable power supply without monitoring possibilities, but to monitor (both locally and remotely) an EPI MM needs to be fitted.

- The EPI MM is available in two versions, one for 1 phase PDU:s and one for 3 phase PDU:s:
 - EPI MM 1 G2 – for 1 phase PDU:s
 - EPI MM 3 G2 – for 3 phase PDU:s
- Possible to fit EPI MM monitoring module for IP monitoring of:
 - Input voltage [V]
 - Total load current [A]
 - Total power [kW]
 - Energy consumption [kWh]
- TCP/IP connection
- Local monitoring directly on the monitoring module [EPI MM G2]
- Embedded controlling software [html] for configuration and alarm threshold setting.
- SNMP monitoring.

EPI AM, AMPERE MODULE

Each EPI PDU can be used alone to provide reliable power supply without monitoring possibilities, but to monitor the load locally an EPI AM needs to be fitted.

- The EPI AM is available in two versions, one for 1 phase PDU:s and one for 3 phase PDU:s:
 - EPI AM 1 G2 – for 1 phase PDU:s
 - EPI AM 3 G2 – for 3 phase PDU:s
- Possible to fit EPI AM ampere module for local reading of:
 - Total load current [A]



EPI MM REMOTE MONITORING

Each EPI MM can be monitored via html or SNMP through IP.

Through the html interface it is possible to:

- Monitor device state
- Set alarm thresholds



Monitor device state



Set alarm thresholds



EPI PDU RANGE AND ACCESSORIES



EPI 8 16A G2 • IN: C20, 16A OUT: 8xC13



EPI MM 1/3 G2 • Monitoring Module for 1 phase or 3 phase EPI G2 PDU:s



EPI 24+6 16A G2 • IN: IEC60309, 16A OUT: 24xC13, 6xC19



EPI AM 1/3 G2 • Ampere Module for 1 phase or 3 phase EPI G2 PDU:s



EPI 24+6 32A G2 • IN: IEC60309, 32A OUT: 24xC13, 6xC19



EPI 24+6 3x16A G2 • IN: IEC60309, 3x16A OUT: 24xC13, 6xC19

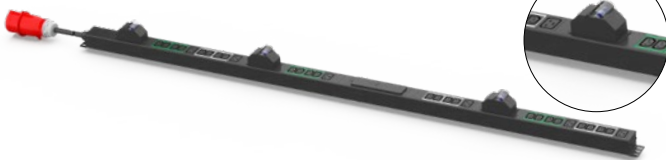

EPI 42+4 32A G2 • IN: IEC60309, 32A OUT: 42xC13, 4xC1



TECHNICAL DATA - EPI POWER DISTRIBUTION UNITS

NAME	ART. NO.	EAN	E NUMBER	IN	OUT C13	OUT C19	LENGTH (mm)
EPI 8 16A G2	54361	7330701031519	2502090	C20 16A	8	-	483
EPI 24+6 16A G2	54362	7330701031526	2502091	IEC60309 16A	24	6	1328
EPI 24+6 32A G2	54363	7330701031533	2502092	IEC60309 32A	24	6	1453
EPI 24+6 3x16A G2	54364	7330701031540	2502093	IEC60309 3x16A	24	6	1378
EPI 24+6 3x32A G2	54365	7330701031557	2502094	IEC60309 3x32A	24	6	1737
EPI MM 1 G2	54366	7330701031564	2502095	-	-	-	172
EPI MM 3 G2	54367	7330701031571	2502096	-	-	-	172
EPI AM 1 G2	54368	7330701031588	2502097	-	-	-	172
EPI AM 3 G2	54369	7330701031595	2502098	-	-	-	172

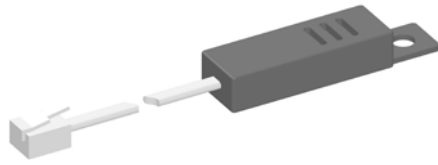

EPSE 1

Temp/Humidity sensor with 2m cable. To be fitted in EPI MM G2.



EPB C19-SCHUKO/FRENCH

Conversion cable from C19 to Schuko/French plug. To be fitted at C20 plug.



EPB C19-C14

Conversion cable from C19 to C14 plug. To be fitted at C20 plug.

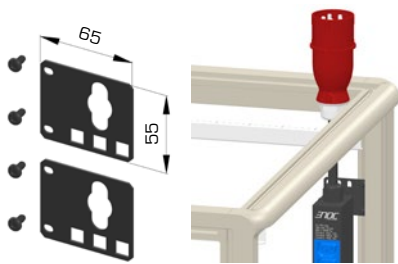

EPMB X1-S

Mounting bracket for fitting accessories in the corner post of the X1 frame. Delivered as a pair.

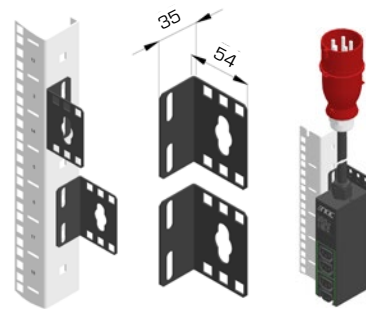

EPVB X1-S

Mounting bracket for fitting accessories on the side of the 19" profiles. Delivered as a pair.



EPMB-2 X1-S

Mounting bracket for fixing accessories vertically along the corner post. Delivered as a pair.

TECHNICAL DATA - ACCESSORIES

NAME	ART. NO.	EAN	E NUMBER	DESCRIPTION
EPSE 1	54490	7330701031403	2597747	Temp/Humidity sensor, 2m cable
EPB C19-Schuko/French	54488	7330701031380	2500086	Conversion cable, 0,2 m
EPB C19-C14	54489	7330701031397	2500087	Conversion cable, 0,2 m
EPMB-2 X1-S	54500	7330701031502	2503745	
EPMB X1-S	54499	7330701031496	2597987	Mounting bracket Cornerpost, 1 PDU, Pair
EPVB X1-S	56566	7330701090653	2500806	Mounting bracket PR, Pair



CT CABLE TRAY SYSTEM, GENERATION 2

We are introducing an updated range of our popular CT1, CT3 and CT5 products. Generation 2 comes with a new lid and hinge. More sizes, 21 and 26 HU version, besides existing 42 and 47 HU versions. 42 and 47 HU sizes are now divided into 2 pcs for easier transport and storage.

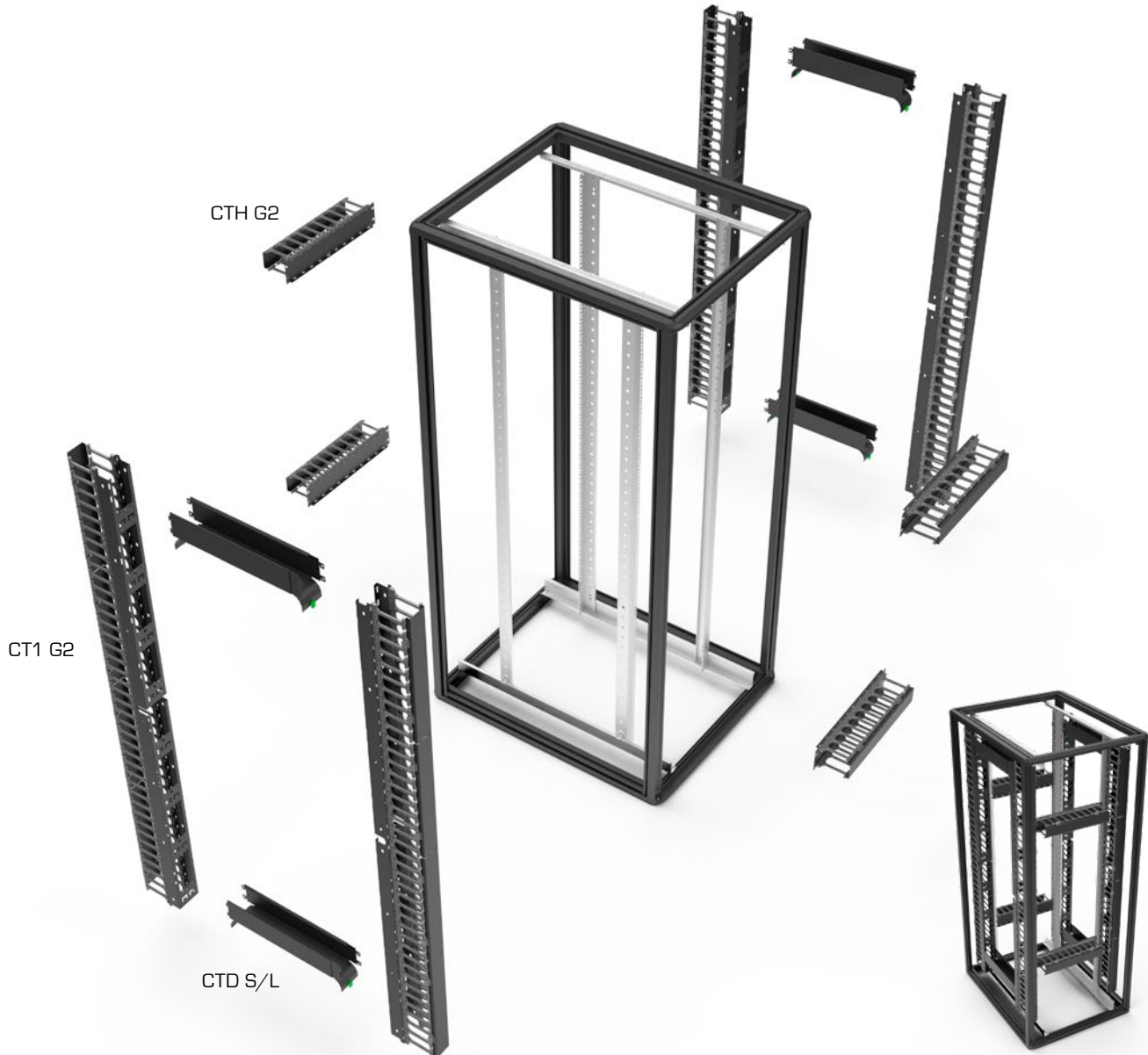

THE ENOC CABLE TRAY SYSTEM MEETS YOUR DIFFERENT NEEDS

CT1 G2 Cable Tray Vertical with premium functions and possibilities.

CT3 G2 Cable Tray Vertical with standard functions, delivered as a pair.

CT5 G2 Cable guide without tray, delivered as a pair.

CTH G2 Cable Tray Horizontal. 19" 2HU cable tray.

CTD S Cable Tray Depth, size small. For supporting cables in the depth direction.

CTD L Cable Tray Depth, size large. For supporting cables in the depth direction.

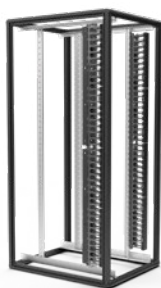

PREMIUM – CT1 G2

High end vertical cable tray. Fits on the left and right side of the 19" profile in F1, S1 and F3 cabinets.

- Metal tray with plastic fingers and metal lid.
- Available in 21, 26, 42 HU and 47 HU version.
- 21, 26 HU version with 2 lids and 42, 47 HU version with 4 lids.
- Lids are hinged both left and right. They can also be removed completely.
- Back of tray have openings for cables going in the depth direction. It is also equipped with holes for cable holders.
- 42 and 47 HU versions are divided into 2 parts, which can be placed individually.
- Possible to fit CTDS/L in the back of the tray.
- KM cagenut fixing (not included).
- Delivered 1 pc.

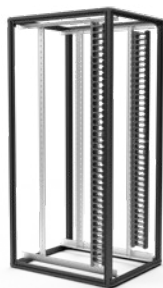
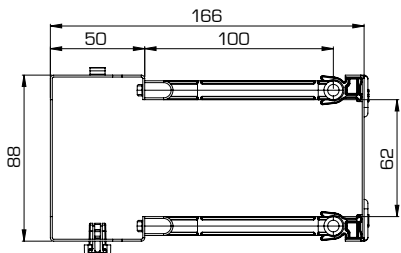

STANDARD – CT3 G2

Standard vertical cable tray. Fits on the left and right side of the 19" profile in F1, S1 and F3 cabinets.

- Metal tray with plastic fingers and metal lid.
- Available in 21 and 42 HU version.
- 21 HU version with 1 lid and 42 HU version with 2 lids.
- Lid is hinged on both left and right. It can also be removed completely.
- 42 HU version is divided into 2 parts, which can be placed individually.
- KM cagenut fixing (not included).
- Delivered 1 pc.

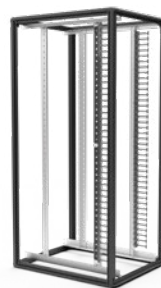
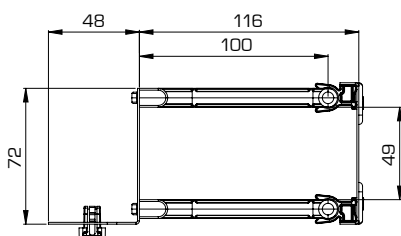

BASIC – CT5 G2

Basic vertical cable manager without tray. Fits on the left and right side of the 19" profile in F1, S1 and F3 cabinets.

- Metal holder with plastic fingers.
- Available in 21, 26, 42 and 47 HU version.
- 42 and 47 HU version is divided into 2 parts, which can be placed individually.
- KM cagenut fixing (not included).
- Delivered 1 pc.

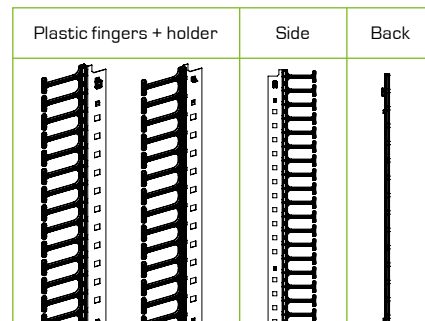
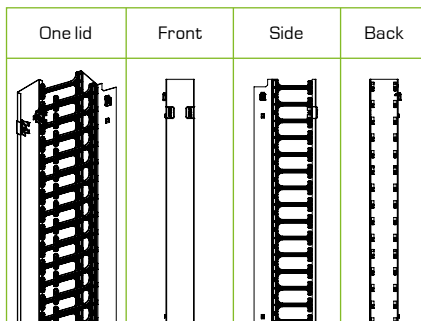
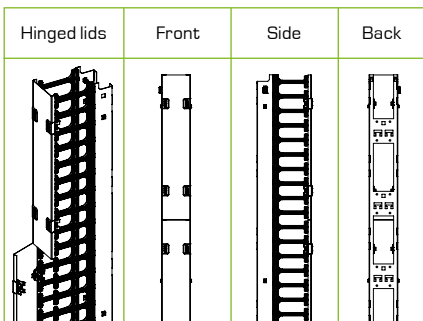
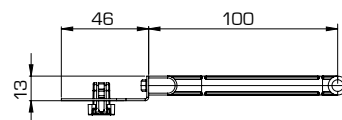

TECHNICAL DATA – CT1 G2, CT3 G2 AND CT5 G2

NAME	ART. NO.	EAN	E NUMBER	WxDxH (mm)	MIN CABINET HEIGHT
CT1 21 G2	56973	7330701106132	2506313	88 x 167 x 888	1200 mm (24 HU)
CT1 26 G2	56974	7330701106149	2506314	88 x 167 x 1110	1400 mm (29 HU)
CT1 42 G2	56975	7330701106156	2506315	88 x 167 x 1777	2000 mm (42 HU)
CT1 47 G2	56976	7330701106163	2506316	88 x 167 x 1999	2200 mm (47 HU)
CT3 21 G2	56979	7330701106194	2506317	72 x 165 x 888	1200 mm (24 HU)
CT3 42 G2	56981	7330701106217	2506318	72 x 165 x 1777	2000 mm (42 HU)
CT5 21 G2	56984	7330701106248	2506319	13 x 151 x 888	1200 mm (24 HU)
CT5 26 G2	56985	7330701106255	2506320	13 x 151 x 1110	1400 mm (29 HU)
CT5 42 G2	56986	7330701106262	2506321	13 x 151 x 1777	2000 mm (42 HU)
CT5 47 G2	56987	7330701106279	2506322	13 x 151 x 1999	2200 mm (47 HU)



CABLE TRAY SYSTEM ACCESSORIES



CTH G2

Cable tray horizontal. 19" 2HU cable tray using the same components as CT1.

- Metal tray with plastic fingers and metal lid.
- 2 HU, 19" fixing.
- Lid is hinged both top and bottom and can be removed completely.

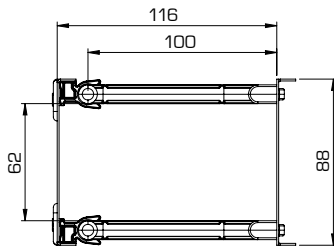

Hinged lid + plastic fingers	
Middle	
Back	



CTD S/L

Cable tray depth. For supporting cables in the depth direction. Either between two CT1 or between one CT1 and a 19" profile.

- Stepless adjustable depth
- Available in two sizes.
- CTD S, 300 - 450 mm depth
- CTD L, 450 - 700 mm depth
- Toolfree fixing in CT1
- KM Cagenut required for fixing in 19" profile (not included)
- Bend radius control built in

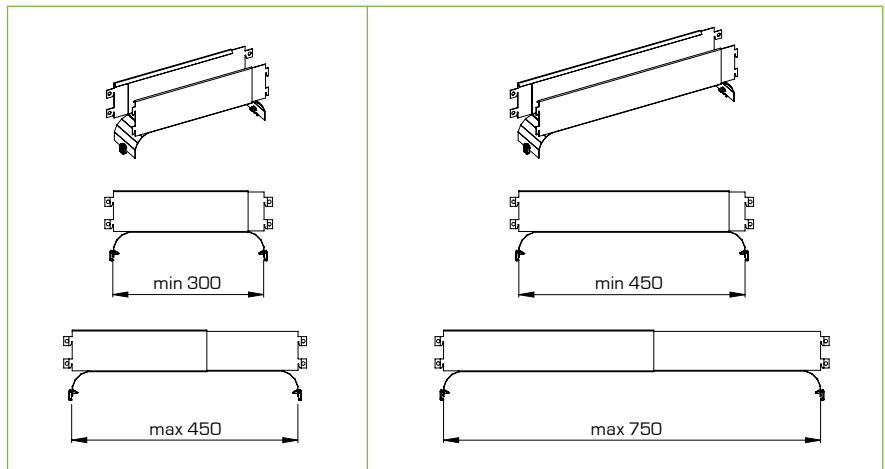
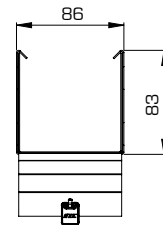

TECHNICAL DATA

NAME	ART. NO.	EAN	E NUMBER	W x D x H (mm)	REMARK
CT1 42	56875	7330701093746	2501235	88 x 166 x 1777	1 pcs, 2000 mm F1
CT1 47	56876	7330701093753	2501236	88 x 166 x 1998	1 pcs, 2200 mm F1
CT3 42	56881	7330701093807	2501237	75 x 165 x 1777	Pair, 2000 mm F1
CT3 47	56882	7330701093814	2501277	75 x 165 x 1998	Pair, 2200 mm F1
CT5 42	56886	7330701093852	2501238	13 x 151 x 1777	Pair, 2000 mm F1
CT5 47	56887	7330701093869	2501278	13 x 151 x 1998	Pair, 2200 mm F1
CTH G2	56991	7330701106316	2506323	482 x 127 x 88	19", 2HU
CTD S	56896	7330701093951	2501240	86 x 300 x 132	1 pcs, 300-450 mm
CTD L	56897	7330701093968	2501241	86 x 450 x 132	1 pcs, 450-700 mm



AIR CONTROL ACCESSORIES

A range of cover panels for air control.

TPP COVER PANEL 19"

- Made of plastic. All included materials are free from halogen and chlorine compounds.
- The product's fire safety properties are tested according to IEC 60695-11-10/UL94.
- Blank cover panel.
- Tool-free mounting in 19" profiles.
- Can also be used with cable ring KPB as a cable panel.

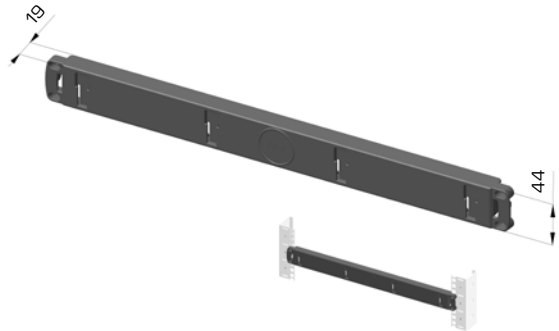

TECHNICAL DATA – TPP BLACK

NAME	ART. NO.	EAN	WxDxH (mm)	NUMBER OF	HU
TPP 01-S	54802	7330701026515	485 x 19 x 44	10	1
TPP 01-S	54803	7330701026522	485 x 19 x 44	126	1

TPS/TPSK G2 AIR GUIDING KIT, GENERATION 2

- Cover panel kit for obstructing airflow from back to front in S1 server enclosure.
- TPS is a cover panel kit without openings.
- TPSK is a cover panel kit with openings covered in soft rubber for cables from front to back. It contains 3 x 1HU vertically on each side. Each HU is covered with TPS blind panel.
- All fixing material included.
- Manufactured in steel sheet.
- Surface treatment, black structured paint RAL9005.

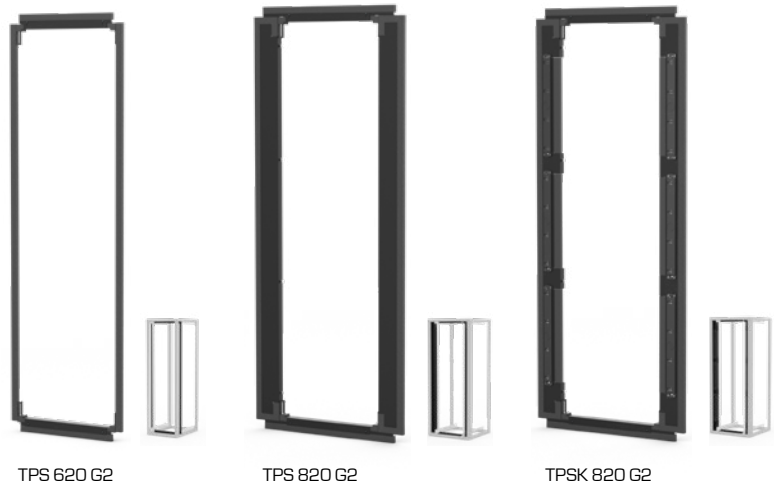

TECHNICAL DATA – TPS/TPSK G2 BLACK

NAME	ART. NO.	EAN	E NUMBER	F1/S1 WIDTH (mm)	F1/S1 HEIGHT (mm)
TPS 620/622 X1-S G2	56586	7330701090851	2503805	600	2000/2200
TPS 820 X1-S G2	56587	7330701090868	2503806	800	2000
TPSK 820 X1-S G2	56588	7330701090875	2503807	800	2000
TPS 822 X1-S G2	56589	7330701090882	2503808	800	2000
TPSK 822 X1-S G2	56590	7330701090899	2503809	800	2000



THE ENTIRE SUPPLY CHAIN

Enoc takes care of the entire supply chain and ensures that the customer's needs and wishes are in focus. We take responsibility all the way from project planning to on-site assembly. Fast and smooth for our customers with deliveries on time and quality-assured assembly on site. Smart and safe for everyone.







THE ENOC WAY

Enoc is the leading manufacturer of enclosures and accessories for computer installations. The company has its headquarters in Sweden and sales offices in Germany and representatives in five other countries. Our production is based on a flexibility and ability to quickly customize the manufacture to markets demand. Products are characterized by quality, detail flexibility and design. At Enoc we are committed to finding the solution that best fits you. That is what we call "The Enoc way".

ENOC

DETAILS MAKE THE DIFFERENCE

Enoc System, Box 159
SE-334 23 Anderstorp, Sweden
Tel: +46 (0)371-588 160
enocsystem.com

